

# KGK JET CCS3100/3000L

Use of the fluorine material for the printhead delivers printing stability.

Being compactly designed the printhead enables to make small print of 1mm or smaller with multiple controlling functions and pigment ink supported.

Catalogue No.7260E

<http://www.kishugiken.co.jp/>

## Equipped with multiple controlling functions.

A master printer to control multiple number of slave printers

- A master printer to control up to 16 slave printers. Controllable functionality is limited.

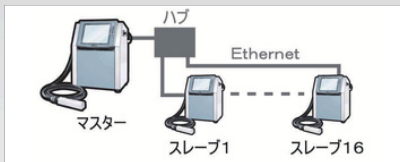

Latest standard model  
CCS3100

Launching a new design of the printhead that assure much improved high definition printing to cope with high speed production line and multiple line printing .



- KGK makes the difference. First in the industrial printing industry! Our printing nozzle made of fluorine material assures stability in printing and eliminates nozzle contamination. Further, improved functionality of the printhead heater and the unique viscosity control system contribute to assured printing stability. No viscosity adjustment will be required with the changing temperature of the environment .

- A lens is equipped with the printhead cover Thus, you can observe ink droplet condition clearly during the maintenance service works.

- Printing speed increased by 30% compared with our other models.

- Nozzle capping system.

- 10.4" removable touch panel is our standard with CCS3100.



CCS3000L a more affordable model



| Model                                                                                 | CCS3100                                                                                                                                                                                                                                                                                                                                                                                                                                                                               | CCS3000L                                                                                      |
|---------------------------------------------------------------------------------------|---------------------------------------------------------------------------------------------------------------------------------------------------------------------------------------------------------------------------------------------------------------------------------------------------------------------------------------------------------------------------------------------------------------------------------------------------------------------------------------|-----------------------------------------------------------------------------------------------|
| Printing method                                                                       | Continuous system (charged control)                                                                                                                                                                                                                                                                                                                                                                                                                                                   |                                                                                               |
| Compatible ink                                                                        | Dye inks and pigment inks                                                                                                                                                                                                                                                                                                                                                                                                                                                             |                                                                                               |
| Dust and water-proof                                                                  | IP65                                                                                                                                                                                                                                                                                                                                                                                                                                                                                  | IP54                                                                                          |
| RoHS directive                                                                        | supported                                                                                                                                                                                                                                                                                                                                                                                                                                                                             |                                                                                               |
| Screen size                                                                           | 10.4" color LCD/ touch panel                                                                                                                                                                                                                                                                                                                                                                                                                                                          | 5.7" color LCD/ touch panel                                                                   |
| Nozzle options                                                                        | 40 μm / 50 μm / 60 μm                                                                                                                                                                                                                                                                                                                                                                                                                                                                 |                                                                                               |
| Print height                                                                          | 0.8 ~ 5mm (40 μm nozzle), 1 ~ 10 mm (50 μm nozzle), 2 ~ 10 mm (60 μm nozzle)                                                                                                                                                                                                                                                                                                                                                                                                          |                                                                                               |
| Maximum printing speed: numbers of characters/second (5x5 dot font with spacing of 1) | 1780 ~ 3200 (depends on nozzles and inks)                                                                                                                                                                                                                                                                                                                                                                                                                                             |                                                                                               |
| Character types                                                                       | alphabetical characters(upper case/lower case), numerical characters, symbols, Japanese hiragana, katakana and kanji of JIS class 1 & 2, User defined characters                                                                                                                                                                                                                                                                                                                      |                                                                                               |
| Number of printing lines and number of dots (vertical x horizontal)                   | [1 to 6 lines] 5 × 5, 5 × N [1 to 4 lines] 7 × 5, 7 × 8, 7 × N [1 to 3 lines] 9 × 7, 9 × 9, 10 × 8, 12 × 1<br>[1 to 2 lines] 16 × 12, 16 × 16 [1 line] 24 × 18, 24 × 24, 32 × 24 ※ 32 × 32 ※                                                                                                                                                                                                                                                                                          |                                                                                               |
| Number of message characters to register                                              | Maximum 4,096 characters                                                                                                                                                                                                                                                                                                                                                                                                                                                              |                                                                                               |
| Number of messages to register                                                        | Maximum 999 messages                                                                                                                                                                                                                                                                                                                                                                                                                                                                  |                                                                                               |
| Date/time (use-by-date)Printing function                                              | Christian calendar year, traditional Japanese calendar year, year/month/date, day of week, time (12/24 hour format, Julian date, serial week number in a year, early/middle/late part of month(variable period setting), AM/PM, Shift code, character assignment function (to assign year/month/date/hour/minute/second/day of week to other character of 4 to 15 digits)                                                                                                             |                                                                                               |
| Numbering function                                                                    | upto 10 digits, setting given initialized value, to run up or down, carry of digit (to set a count by using number of substrates between 1 to 9,999), zero suppressions function (to replace zero of the upper digit with space or to eliminate it), a function to assign the character for numbering (to assign to the character other than numerical character), base setting (binary number to base 38 number), separable (inserting given character between numerical characters) |                                                                                               |
| Distance printing function                                                            | up to 10 digits, separable (inserting given character between numerical characters)                                                                                                                                                                                                                                                                                                                                                                                                   |                                                                                               |
| Barcode printing function                                                             | ITF, Code39, NW7, JAN, Code128                                                                                                                                                                                                                                                                                                                                                                                                                                                        |                                                                                               |
| 2D code printing function                                                             | QR code, data matrix                                                                                                                                                                                                                                                                                                                                                                                                                                                                  |                                                                                               |
| Japanese kana/kanji conversion function                                               | Yes                                                                                                                                                                                                                                                                                                                                                                                                                                                                                   |                                                                                               |
| Connection with external devices                                                      | I/O, signal lamp, RS-232C, LAN, encoder,UPS, USB flash drive                                                                                                                                                                                                                                                                                                                                                                                                                          |                                                                                               |
| Data entry                                                                            | touch panel, RS-232C communications, Ethernet                                                                                                                                                                                                                                                                                                                                                                                                                                         |                                                                                               |
| Communications                                                                        | RS-232C 1CH Maximum 115, 200bps, Ethernet                                                                                                                                                                                                                                                                                                                                                                                                                                             |                                                                                               |
| Printhead cable length                                                                | 3.5m                                                                                                                                                                                                                                                                                                                                                                                                                                                                                  |                                                                                               |
| Multiple head control                                                                 | A master printer can control up to slave printheads<br>[Controllable functions] Start/Stop, Power off, setting system clock, Message selection, Editing printing conditions<br>Setting current value for numbering                                                                                                                                                                                                                                                                    |                                                                                               |
| Dry air source                                                                        | applicable tube outer diameter Φ 6mm or 8mm, air pressure : 0.8Mps or lower (Air ventilator equipped with the main body), air flow : 10 liters/min. (Stirrer equipped with the printer meant for use of pigment ink, 70 liters/min or lower for printers marked ※)                                                                                                                                                                                                                    |                                                                                               |
| Area required for installation (width x depth x height)                               | Main body : 400W × 307D × 548H (excluding protruding objects)<br>Printhead : Φ 49.2mm × 197mm                                                                                                                                                                                                                                                                                                                                                                                         | Main body : 400W × 280D × 532H (excluding protruding objects)<br>Printhead : Φ 49.2mm × 197mm |
| Operating environment (temperature/humidity)                                          | 0 ~ 40 °C (Depends on inks), 10 ~ 85% (no dew condensation)                                                                                                                                                                                                                                                                                                                                                                                                                           |                                                                                               |
| Power source                                                                          | AC90 - 264V(47 - 63Hz), 80W                                                                                                                                                                                                                                                                                                                                                                                                                                                           |                                                                                               |
| Weight                                                                                | 25Kg                                                                                                                                                                                                                                                                                                                                                                                                                                                                                  |                                                                                               |
| Grounding                                                                             | Class D                                                                                                                                                                                                                                                                                                                                                                                                                                                                               |                                                                                               |

※ CCS3100

▼Printhead (CCS3100/3000L)

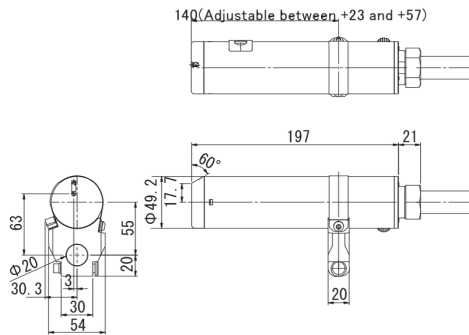

▼ Main body (CCS3100)

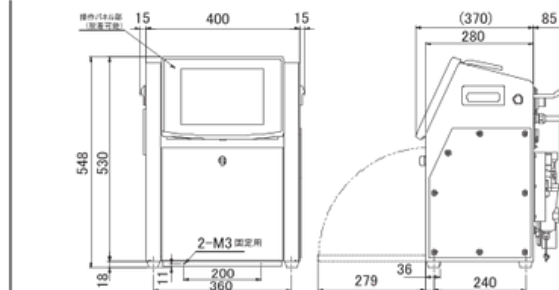

▼ Main body (CCS3000L)

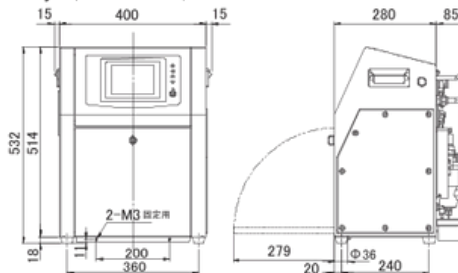

Surrounding areas for installation requires given space. For more details please contact a KGK representative.