

KGK JET CCS2800

KGK is proud to propose use of the most suitable ink among the varieties of KGK developed ones.

No.7255E



Dye based inks and pigment based inks without the use of a stirrer

Pigment based inks with the use of a stirrer

Pigment based inks with the stirrer

Both the dye base inks and the pigment based inks operate with the stable conditions.



- Pigment based inks are also available from KGK

We recommend variety of three printers to cope with among more than 20 kinds of inks available. We propose the most suitable printing. Our printers for use of an electric stirrer for pigment inks will use no external air source.



- The cartridge ink supply system will be used.

Our cartridge ink supply system will keep the operator from dirty hand for ink supply. Our cartridge system enables to save data. Mistakes in cartridge insertion are prevented. Controlling inks by the expiry date is assured.



- New type printhead

Our printhead is built with robust aluminum material. The printhead can be maintained well while it is attached to the stand. Ink flying speed can be stably controlled to assure quality printing.

Printing examples



Automatic Nozzle Capping System

The opening of the ink collection gutter automatically moves to tightly close the nozzle in the printhead when you finish the day's operation.



● Specifications

model	Dye based inks and pigment based inks without the use of a stirrer	Pigment based inks with the use of a stirrer	Pigment based inks with the stirrer
	CCS2800	CCS2800P	CCS2800PS
Printing system	Continuous system (using the charged controlsystem)		
Inks applied to	Dye inks or pigment inks with use of no stirrer	Pigment inks with the circulation stirrer	Pigment inks with the stirrer
Dust proof and waterproof	Not applied		
RoHS	Compliant		
Display size	5.7 inch color CD/touch panel		
Nozzle applicable	40/ 50/ 60μm		
Print height	0.8~5mm (40μm nozzle), 1~10mm(50μm nozzle), 2~10mm(60μm nozzle)		
Maximum printing speed: numbers of characters/second (5x5 dot font with spacing of 1)	Number of characters 2660 to 3200 (Depends on nozzle type and ink used)		
Printable characters	Alphabet (uppercase letters and lowercase letters), numerals, signs, Japanese Hiragana, Japanese Katakana and Kanji of JIS I and II plus user chosen characters		
Number of print lines and dot configuration	[one to five lines] 5x5 [one to 3 lines] 7x5, 7x8		
Number of message characters to register	[one to 2 lines] 9x7, 9x9, 10x8, 12x11 [one line] 16x12, 16x16, 24x18, 24x24		
Number of messages to register	Up to 4096 characters		
	Up to 999 messages		
Printing date and time (best by date)	Christian calendar year, traditional Japanese calendar year, year/month/date, day of week, time (12/24 hour format, Julian date, serial week number in a year, early/middle/late part of month(variable period setting), AM/PM, Shift code, character assignment function (to assign year/month/date/hour/minute/second/day of week to other character of 4 to 15 digits)		
Numbering	upto 10 digits, setting given initialized value, to run up or down, carry of digit (to set a count by using number of substrates between 1 to 9,999), zero suppressions function (to replace zero of the upper digit with space or to eliminate it), a function to assign the character for numbering (to assign to the character other than numerical character), base setting (binary number to base 36number), separable (inserting given character between numerical characters)		
Distance printable	Up to 10 digits, Separable (Given character will be inserted between numerical)		
Bar code printing	ITF, Code39, NW7, JAN, Code128, UPC, Code93		
2D code printing	QR code, DataMatrix		
apanese kana/kanji conversion function	Yes		
Connectivity for external communication	signal light, RS-232C, encoder, UPS, USB memory		
Data input	Touch panel, Communications		
Communications	RS-232C 1CH Up to 115200bps		
Head cable length	3.5m		
Dry air source (for air purging in the printhead)	Compatible tube outside diameter Φ6mm or 8mm Air pressure : 0.8Mps or less Air flow : 10 liters/min or less main body: 370W x 330D x 535H(excluding portions sticking out)		
Areas required for installation (With x depth x height)	Printhead: 50mm x 52mm x 209.5mm main body: 370W x 330D x 635H(excluding portions sticking out)		
Operating environment (temperature/humidity)	0~40 °C(Depinds on the ink used), 10~85% (No dew condensation)		
power source	AC90-264V(47-63Hz), 60W		
weight (main body)	19Kg		
weight (printhead)	870g	21Kg	22Kg
Grounding	type D		

● Dimensional drawing

▶Dye based inks and pigment based inks without the use of a stirrer

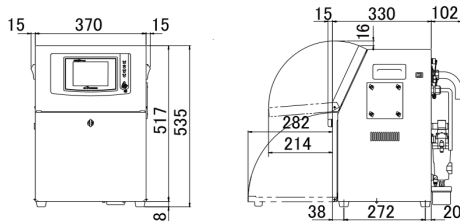

▶Pigment based inks with the use of a stirrer

▶Pigment based inks with the stirrer

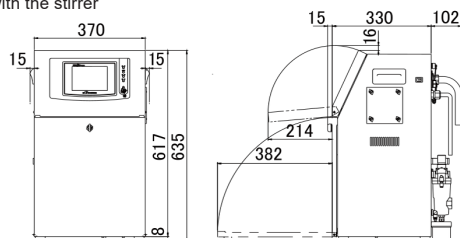

▶printhead

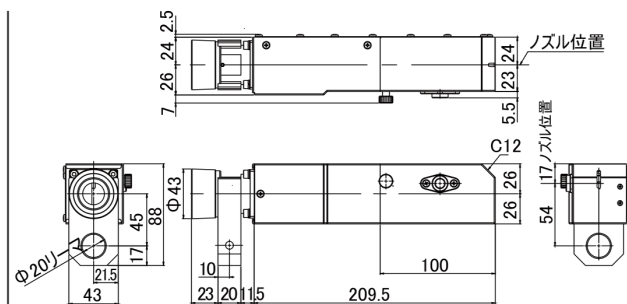

Note: Some additional space required for installation for the main body

※Specifications subject to change without notice.